

Condominium

MODEL A

1-Story · 3 Bedrooms · 2 Baths  
Great Room · Courtyard

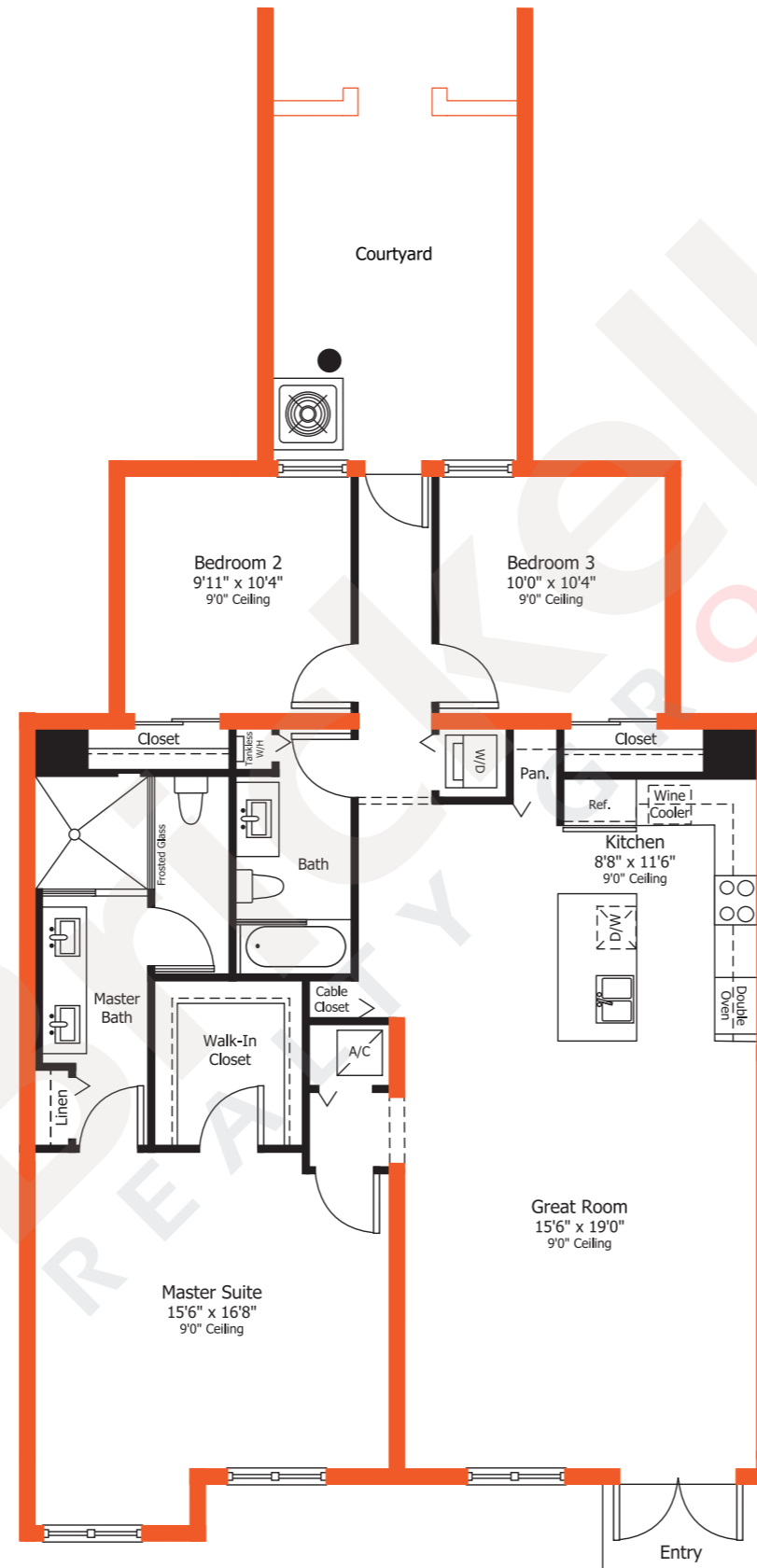

	SQ FT	M <sup>2</sup>
A/C Area	1,367	127.0
Courtyard	180	16.7
<b>Total</b>	<b>1,547</b>	<b>143.7</b>

**Brickell**  
REALTY GROUP

2071 NW 112th Avenue, Miami, FL 33172

[www.brickell-realty.com/Landmark.html](http://www.brickell-realty.com/Landmark.html)

Oral representation cannot be relied upon as correctly stating representations of the developer. Pictures of homes and condos may not reflect and final products may vary. Dimensions, specifications, improvements, rendering, plans, land uses, materials, amenities, prices, and availability are subject to

Condominium

MODEL B

2-Story · 3 Bedrooms · 3 Baths  
Garage

	SQ FT	M <sup>2</sup>
A/C Area	1,547	143.7
Garage	258	24.0
Covered Entry	44	4.1
<b>Total</b>	<b>1,849</b>	<b>171.8</b>

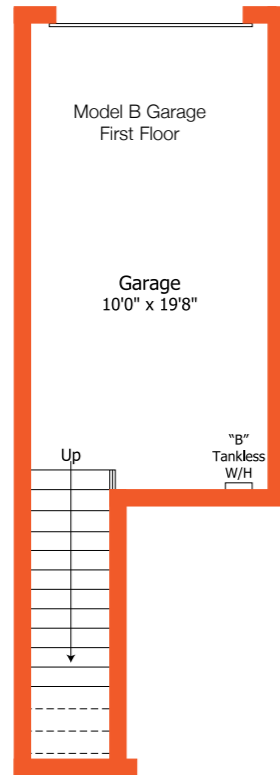

First Floor

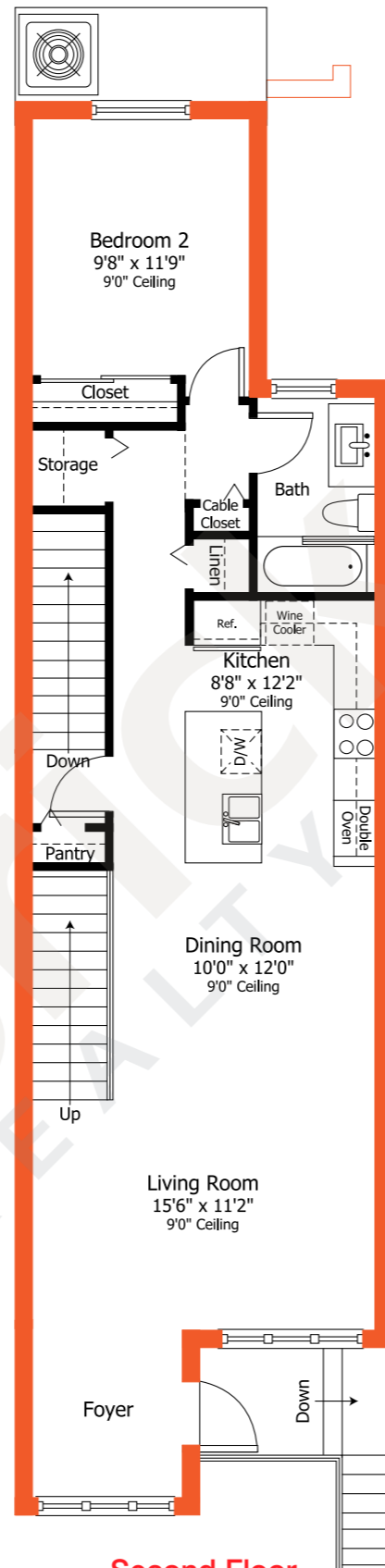

Second Floor

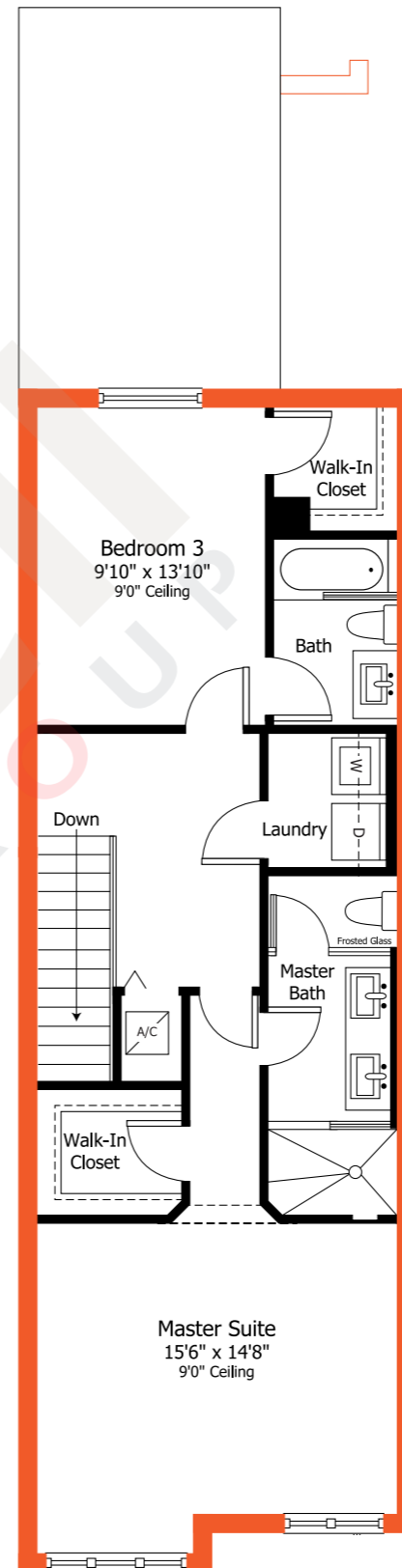

Third Floor

Condominium

MODEL C

2-Story · 3 Bedrooms · 2.5 Baths  
Family Room · Garage

	SQ FT	M <sup>2</sup>
A/C Area	1,689	156.9
Garage	258	24.0
Covered Entry	44	4.1
<b>Total</b>	<b>1,991</b>	<b>185.0</b>

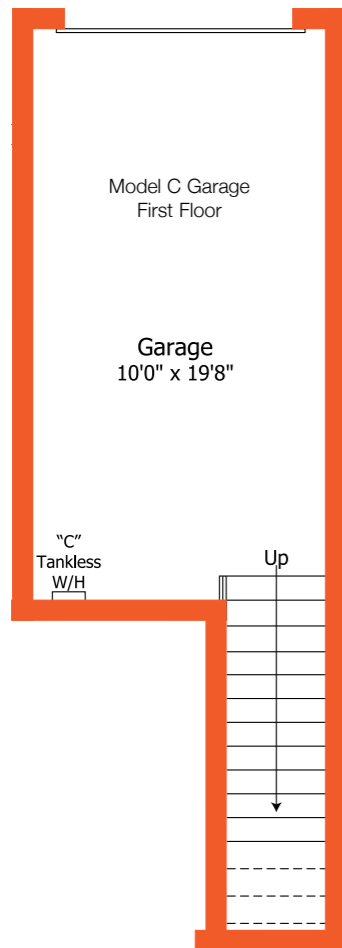

First Floor

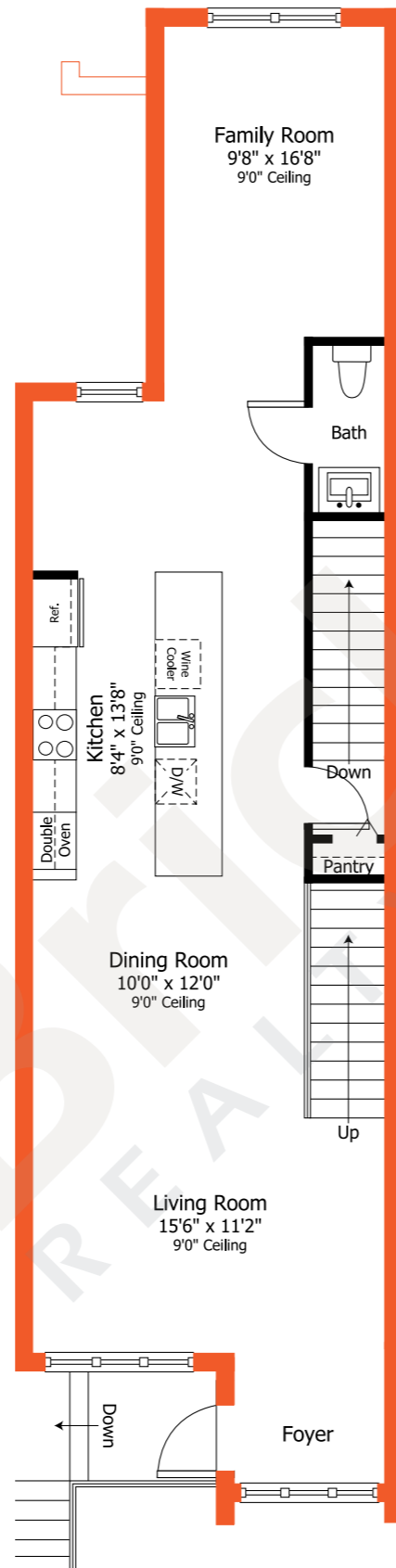

Second Floor

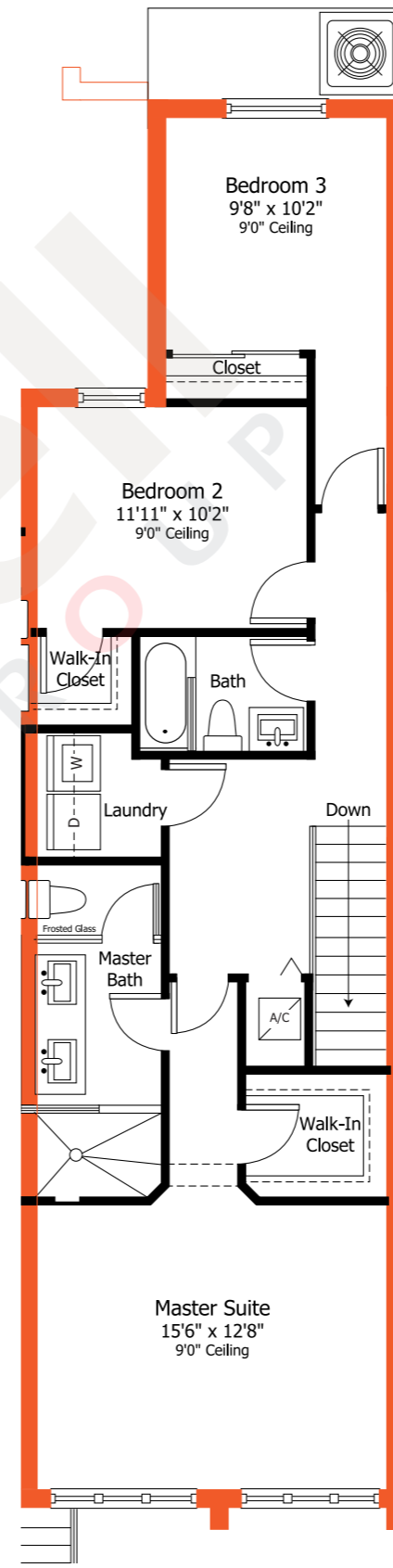

Third Floor

Condominium

MODEL D

1-Story · 3 Bedrooms · 2 Baths  
Great Room

	SQ FT	M <sup>2</sup>
A/C Area	1,102	102.4
Total	1,102	102.4

Available only on 3rd floor and accessible via building elevator or stairs

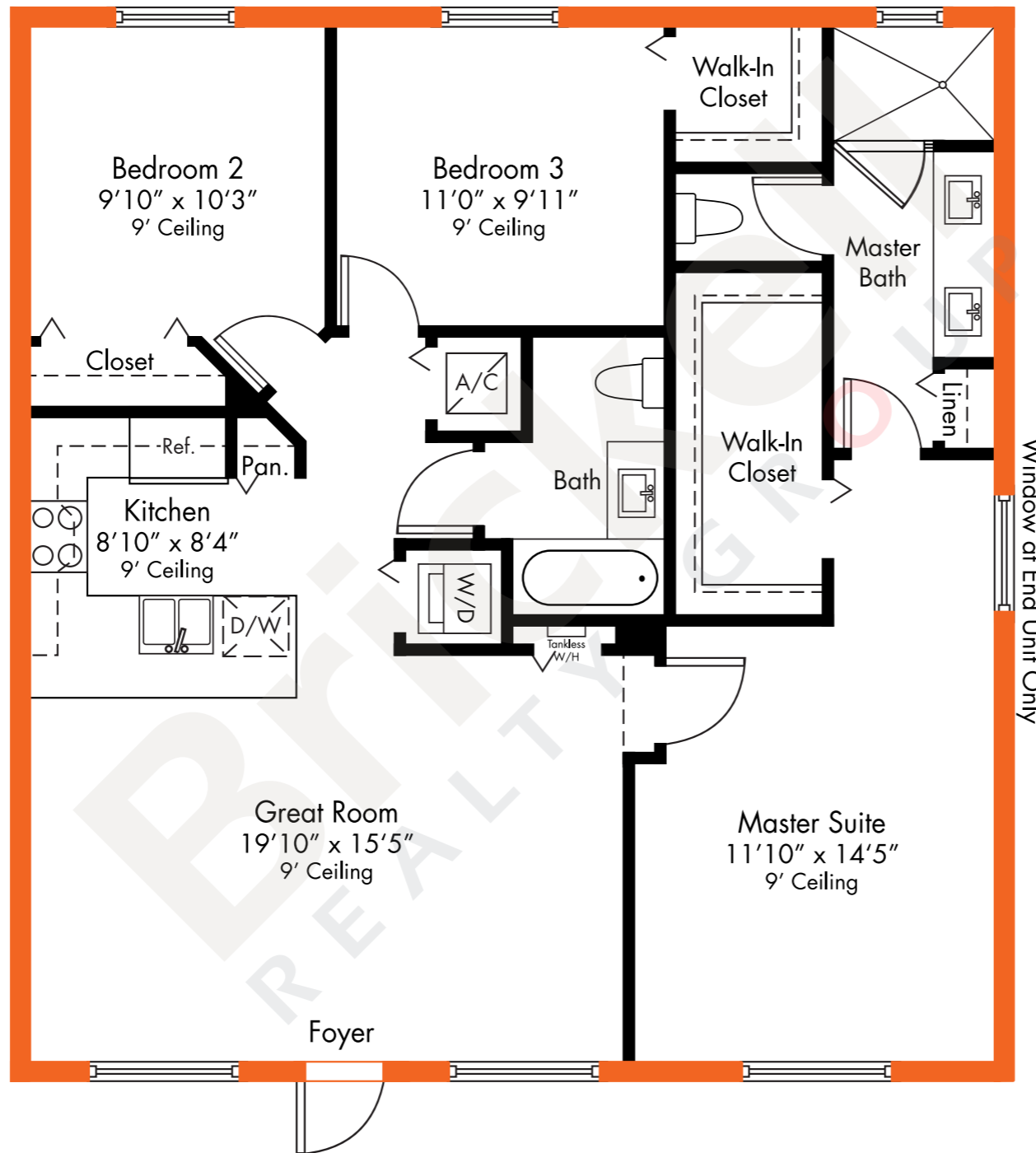

Condominium

MODEL E

2-Story · 3 Bedrooms · 2.5 Baths  
Great Room · Covered Terrace

	SQ FT	M <sup>2</sup>
A/C Area	1,315	122.2
Covered Terrace	152	14.1
Covered Entry	17	1.6
<b>Total</b>	<b>1,484</b>	<b>137.9</b>

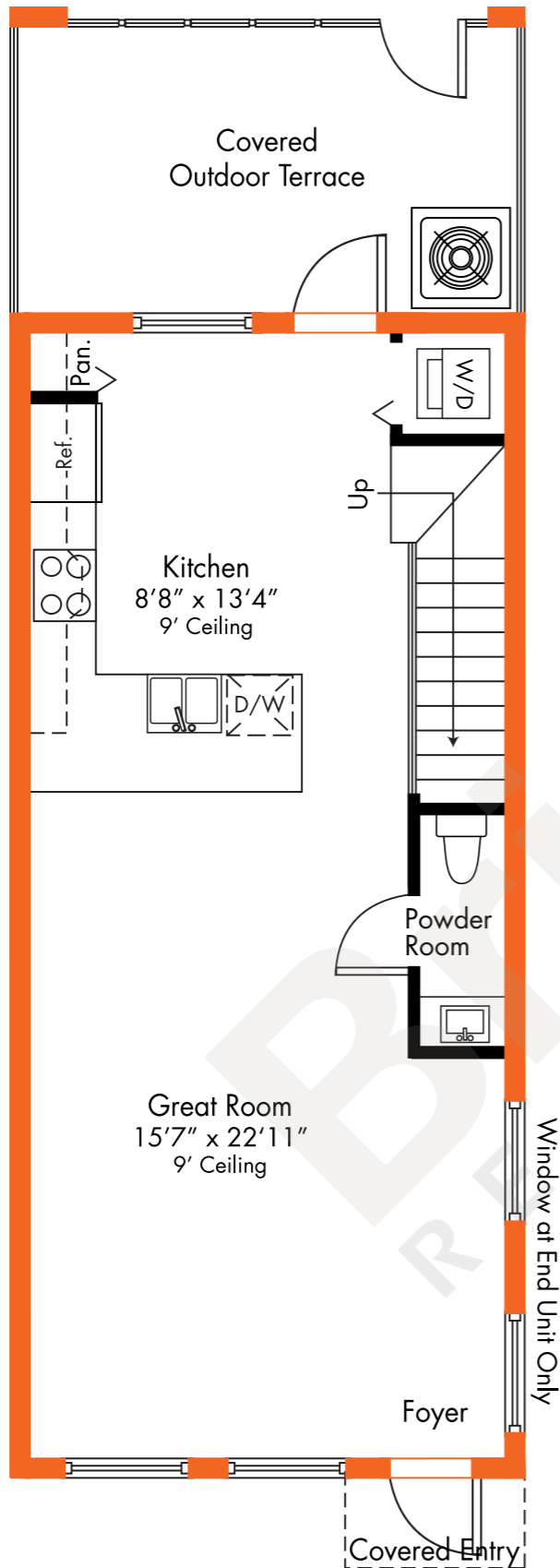

First Floor

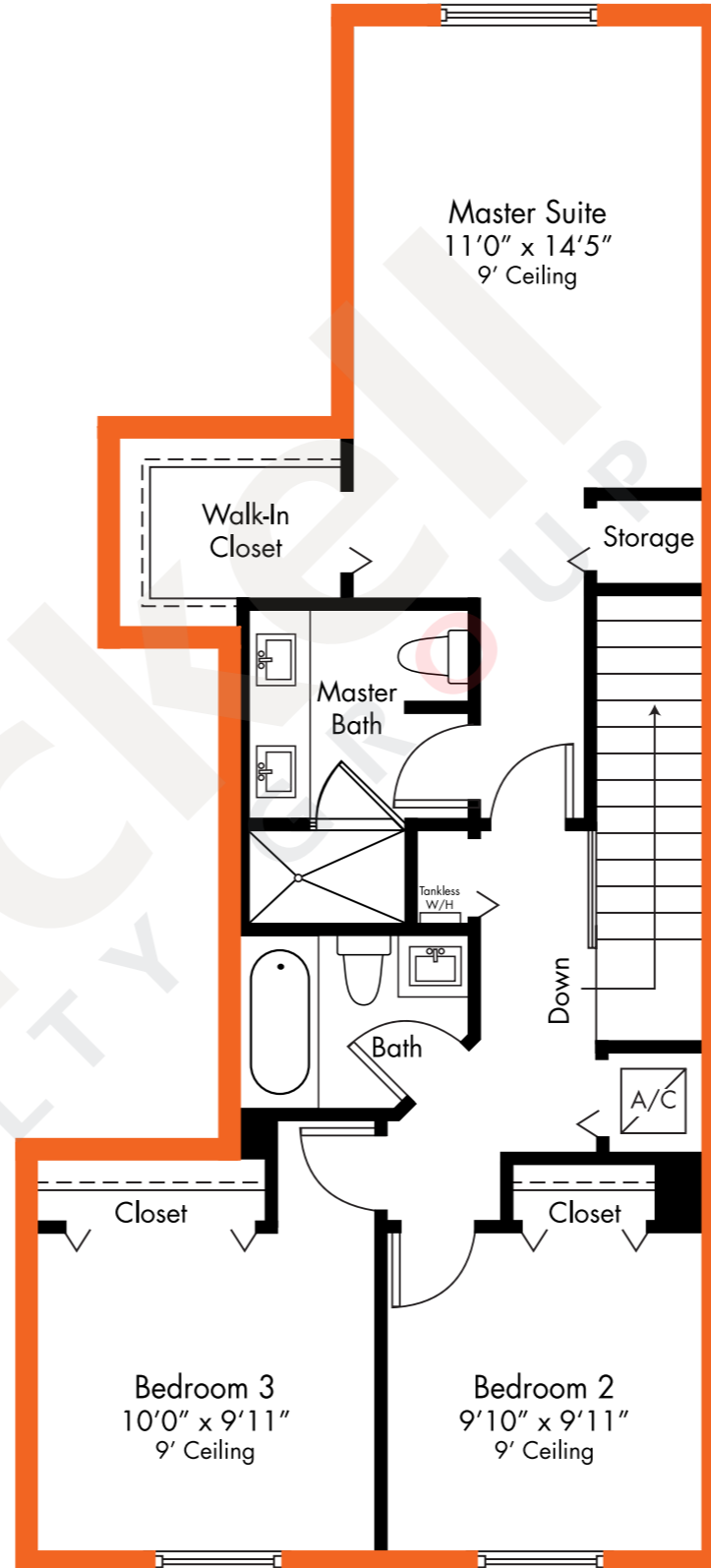

Second Floor

Condominium

MODEL F

2-Story · 3 Bedrooms · 2.5 Baths  
Great Room · Covered Terrace

	SQ FT	M <sup>2</sup>
A/C Area	1,322	122.8
Covered Terrace	152	14.1
Covered Entry	17	1.6
<b>Total</b>	<b>1,491</b>	<b>138.5</b>

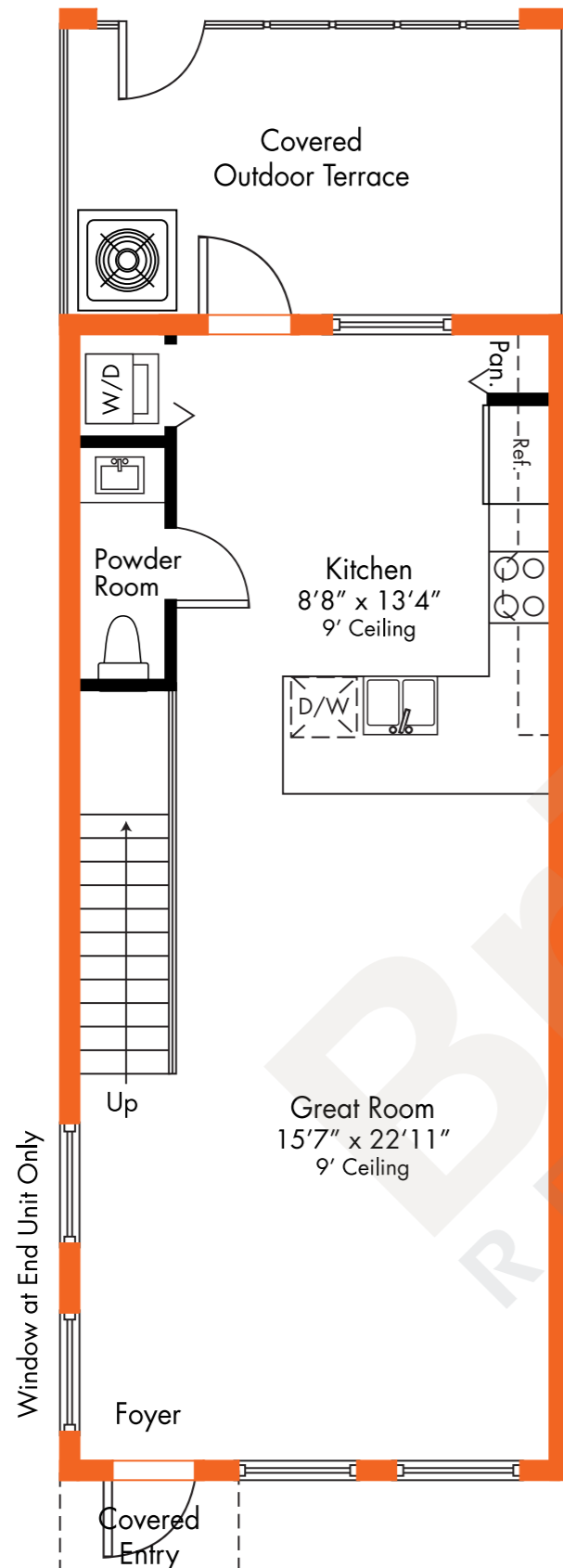

First Floor

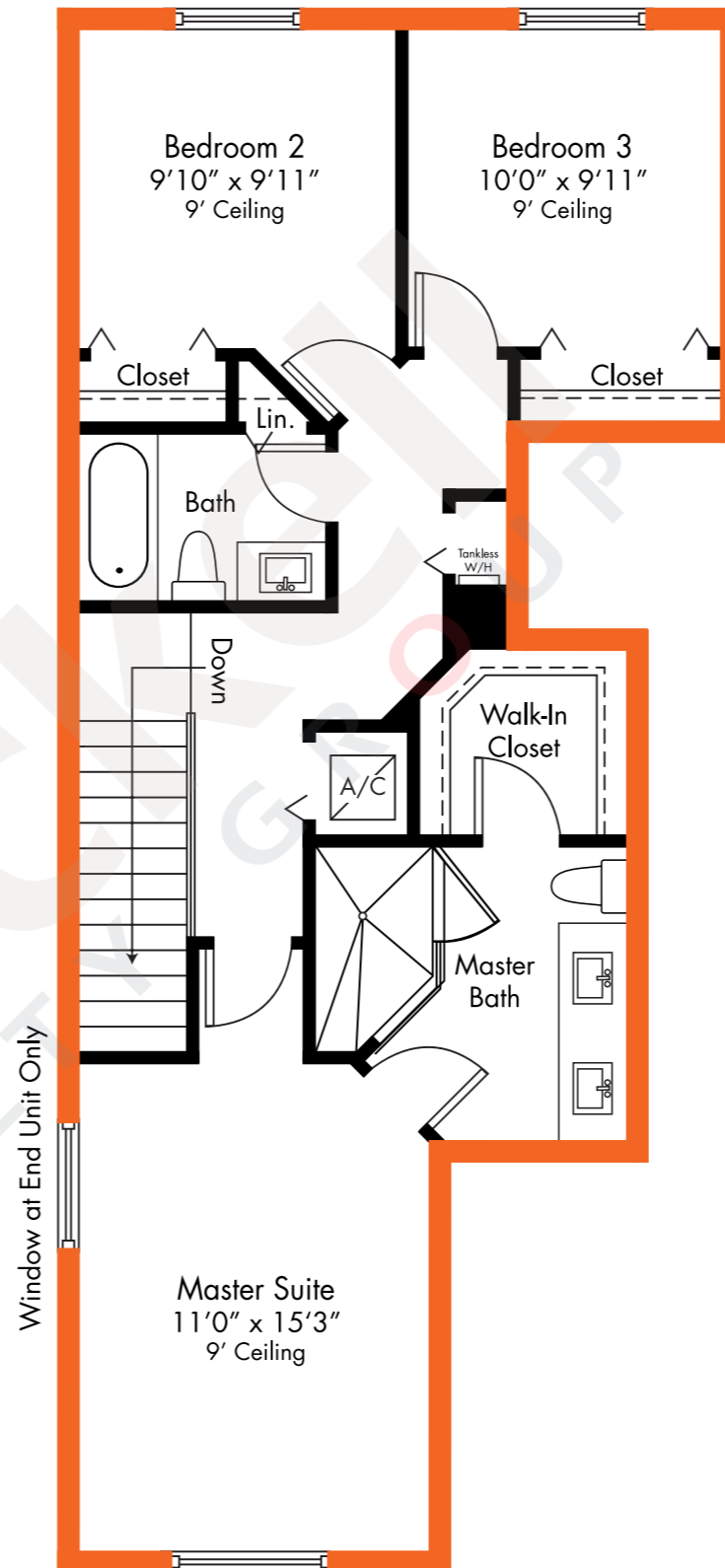

Second Floor