

# *Pine Park*

VILLAS

LIFESTYLE REDEFINED



# OPPORTUNITY

## *Pine Park* VILLAS

### Opportunity (op·er·too·ni·tee)

*Noun:*

A favorable combination of circumstances, time, and place.

Pine Park Villas is available to a lucky few who recognize this singular opportunity to be a part of something new, something innovative, in the Village of Pinecrest. Representing the latest in coastal contemporary design and delivering on-trend finishes, fixtures, and floorplans is a most welcome addition to the Village's limited offering of luxury, multifamily residences.

*'I have been patiently waiting to announce this very special new development in the Village of Pinecrest. It represents my vision for the new standard of luxury living in the Village. My team and I have carefully selected every detail and finish to deliver a beautiful, simple, but elegant design for these 18 new residences, and we look forward to welcoming everyone to this sophisticated new enclave.'*

**Stephane Rosarion**

President and CEO, SCAROFA



# FLOORPLANS

18 exclusive residences delivered to you completely finished and move-in ready. Pine Park Villas' three floorplans offer a perfect alternative to a single-family home. Elevatored three-stories, two-car garages, multi-level living spaces, ample bedrooms with walk-in closets, and private rear yards are the baseline for these unique homes.

## LONGLEAF

**Model units: 6**

- 4 Bedrooms
- 3 Bathrooms
- 2 Powder Rooms
- Den/Media Room

AC	NON A/C	TOTAL
2,881 Sq.Ft.	596 Sq.Ft.	3,477 Sq.Ft.
267.6 Sq.Mt.	55.3 Sq.Mt.	322.9 Sq.Mt.

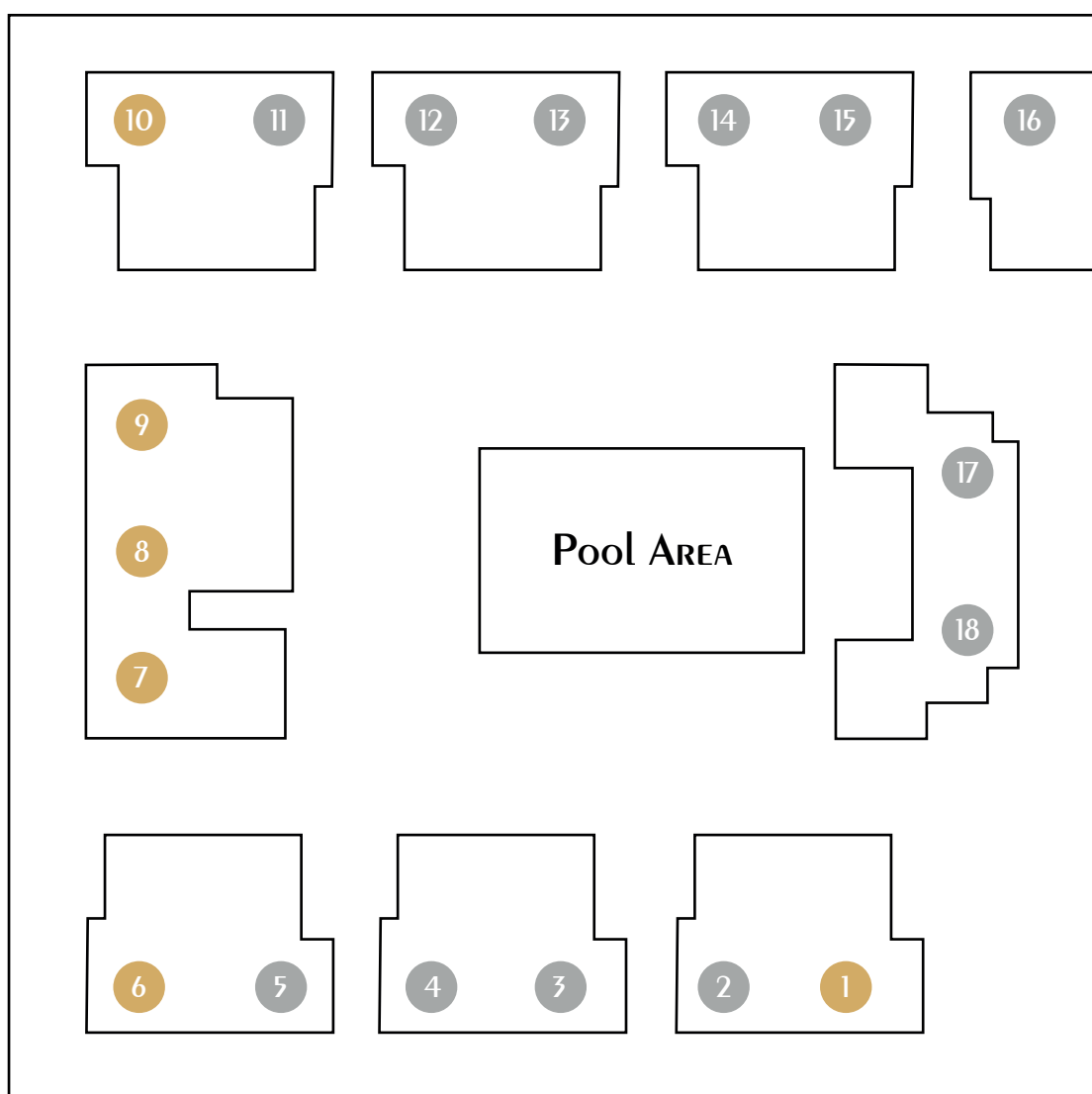

● Longleaf

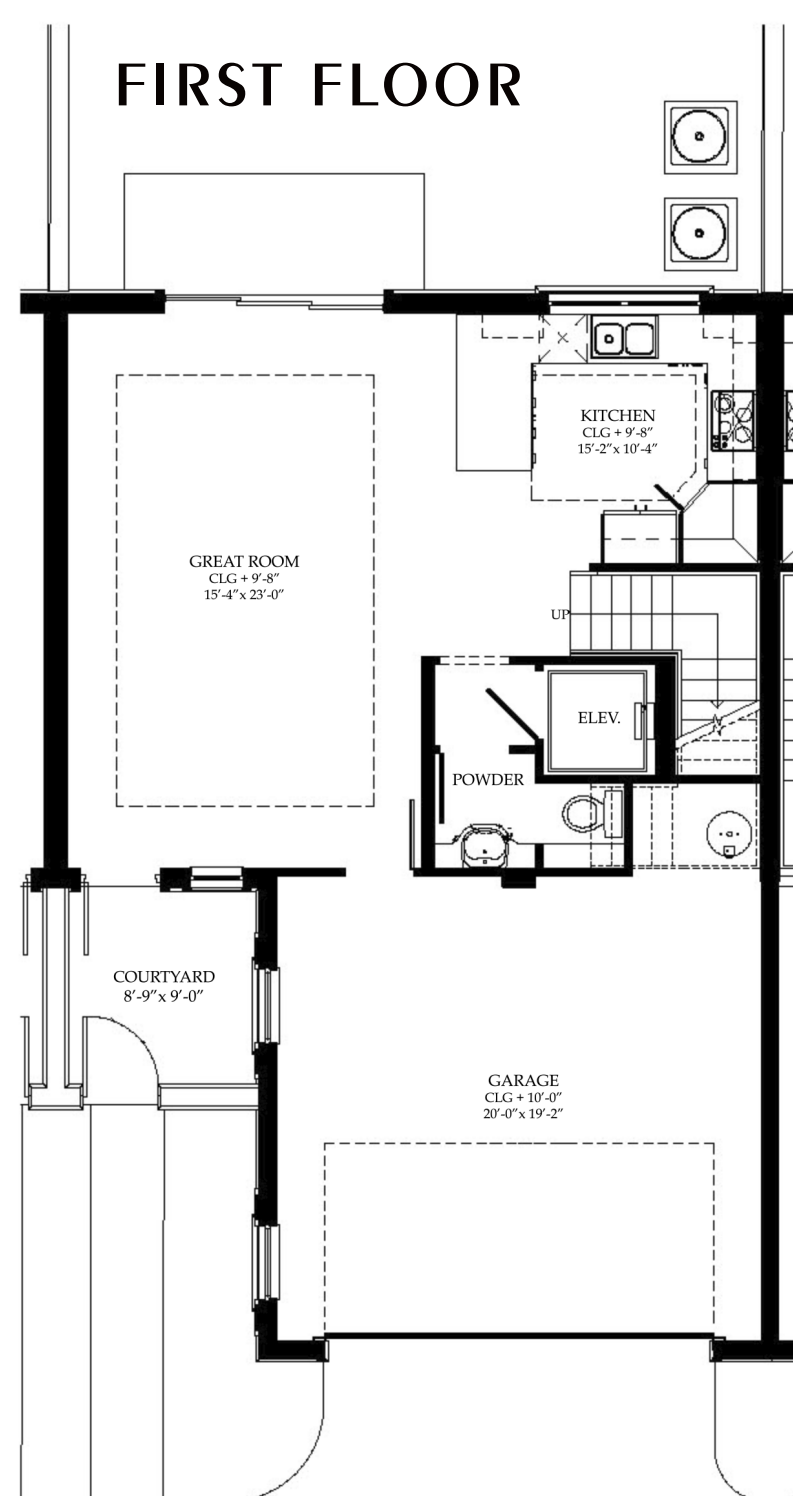

### SECOND FLOOR

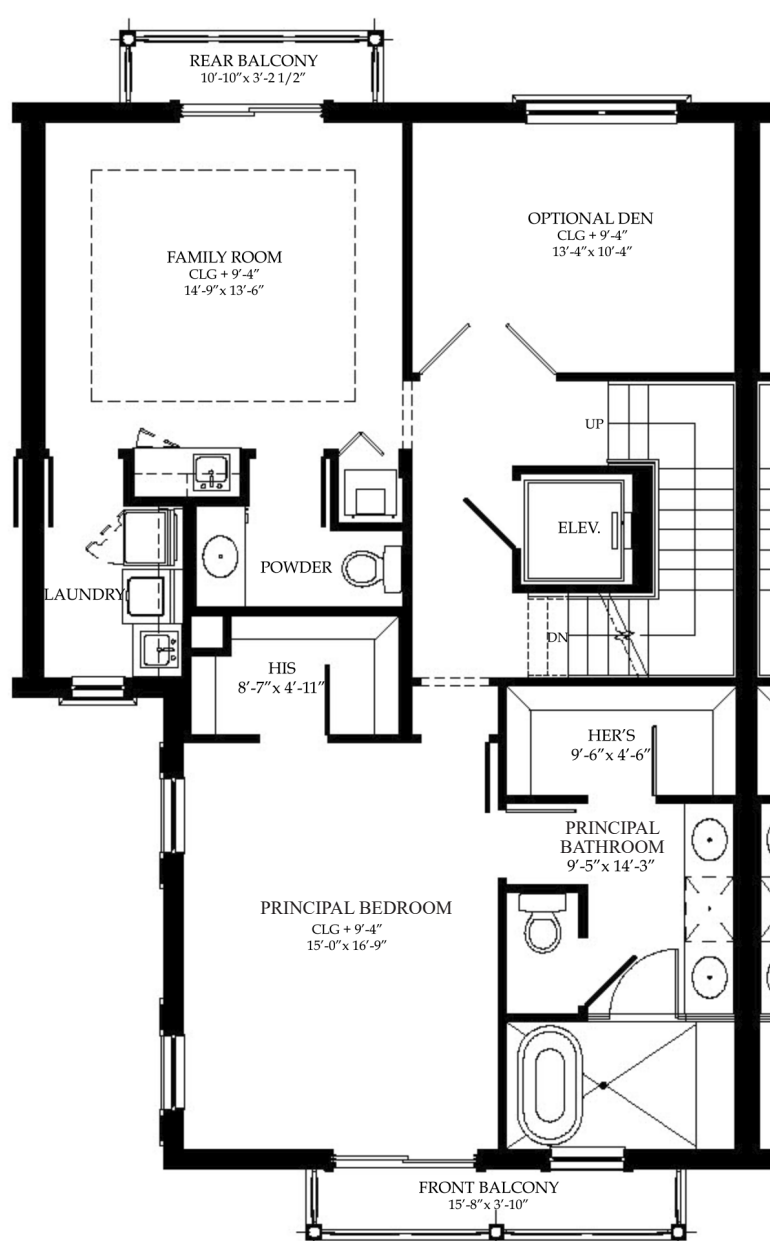

### THIRD FLOOR

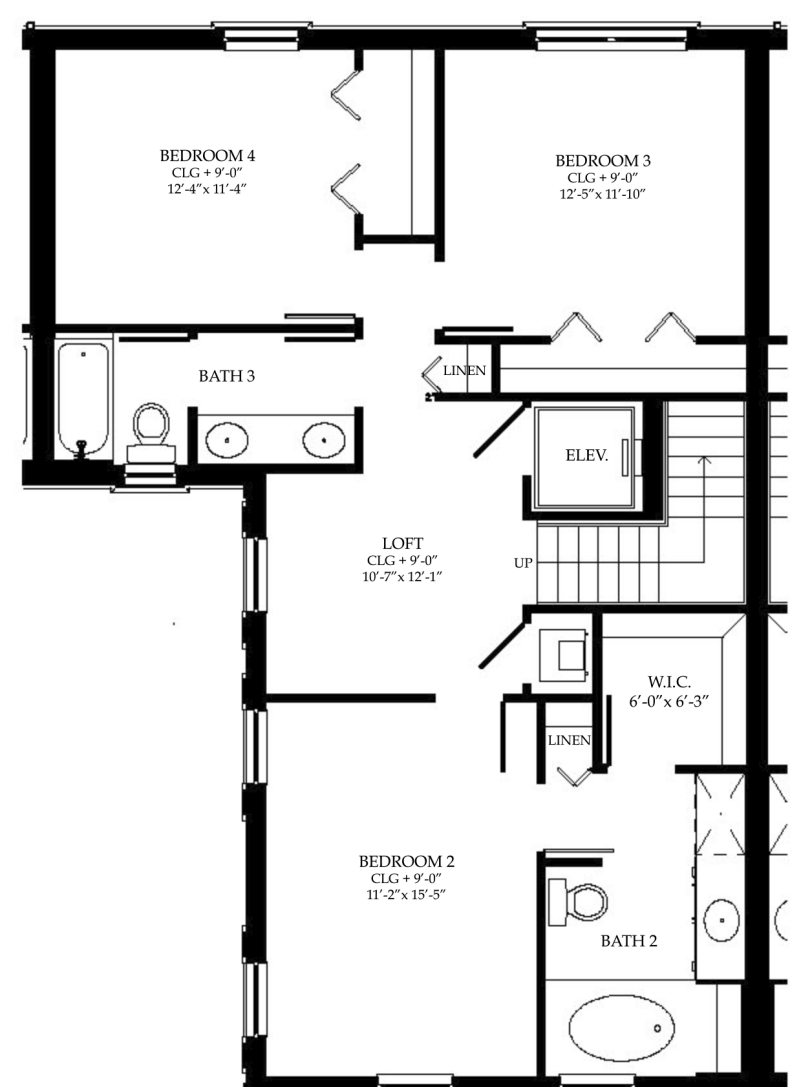

# LONGLEAF

DEN



KITCHEN



PRINCIPAL BEDROOM



# CYPRESS

Model units: 10

4 Bedrooms

3 Bathrooms

2 Powder Rooms

Media/Family Room

AC	NON AC	TOTAL
3,145 Sq.Ft.	580 Sq.Ft.	3,725 Sq.Ft.
292.2 Sq.Mt.	53.8 Sq.Mt.	346 Sq.Mt.

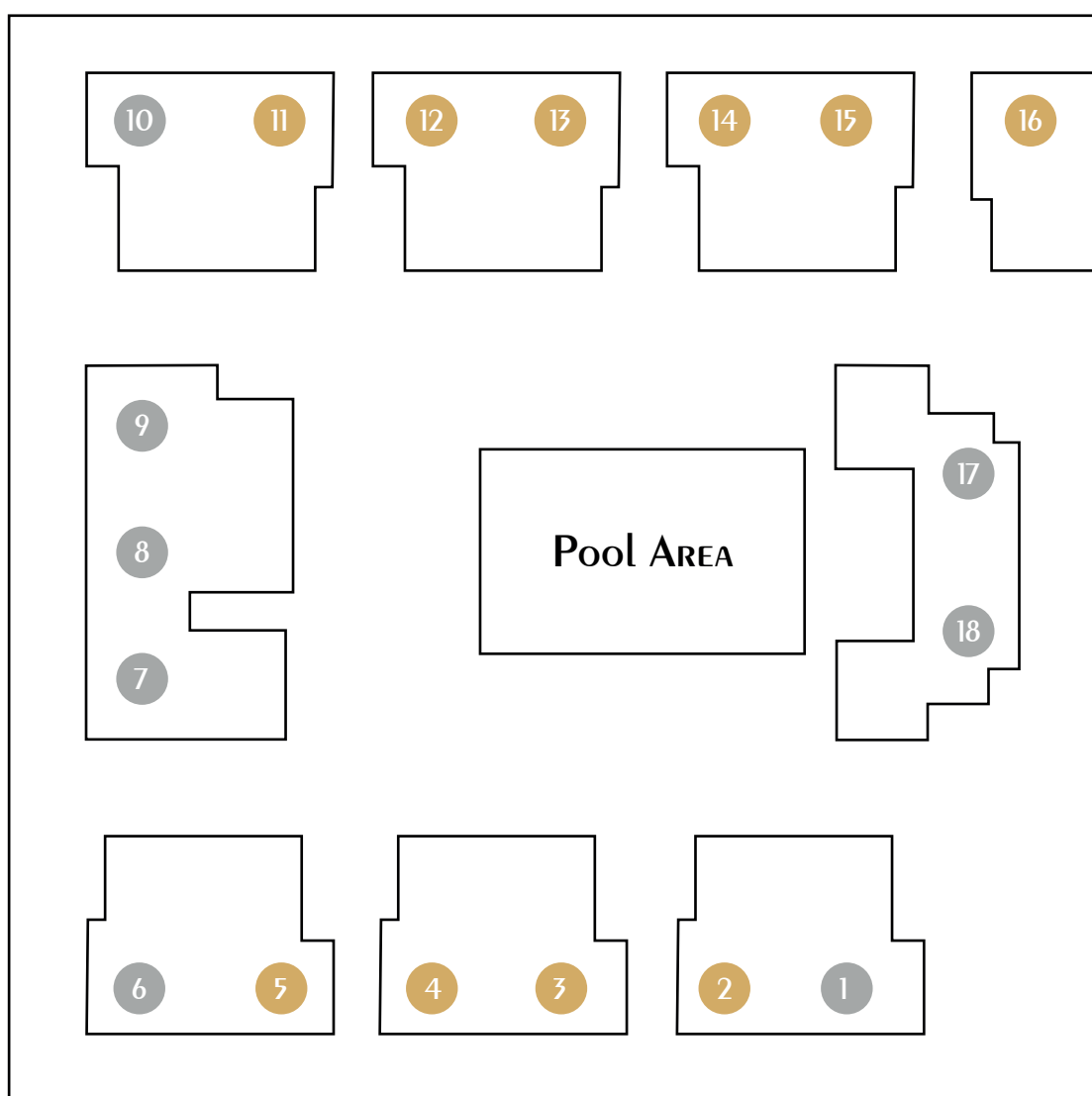

● Cypress

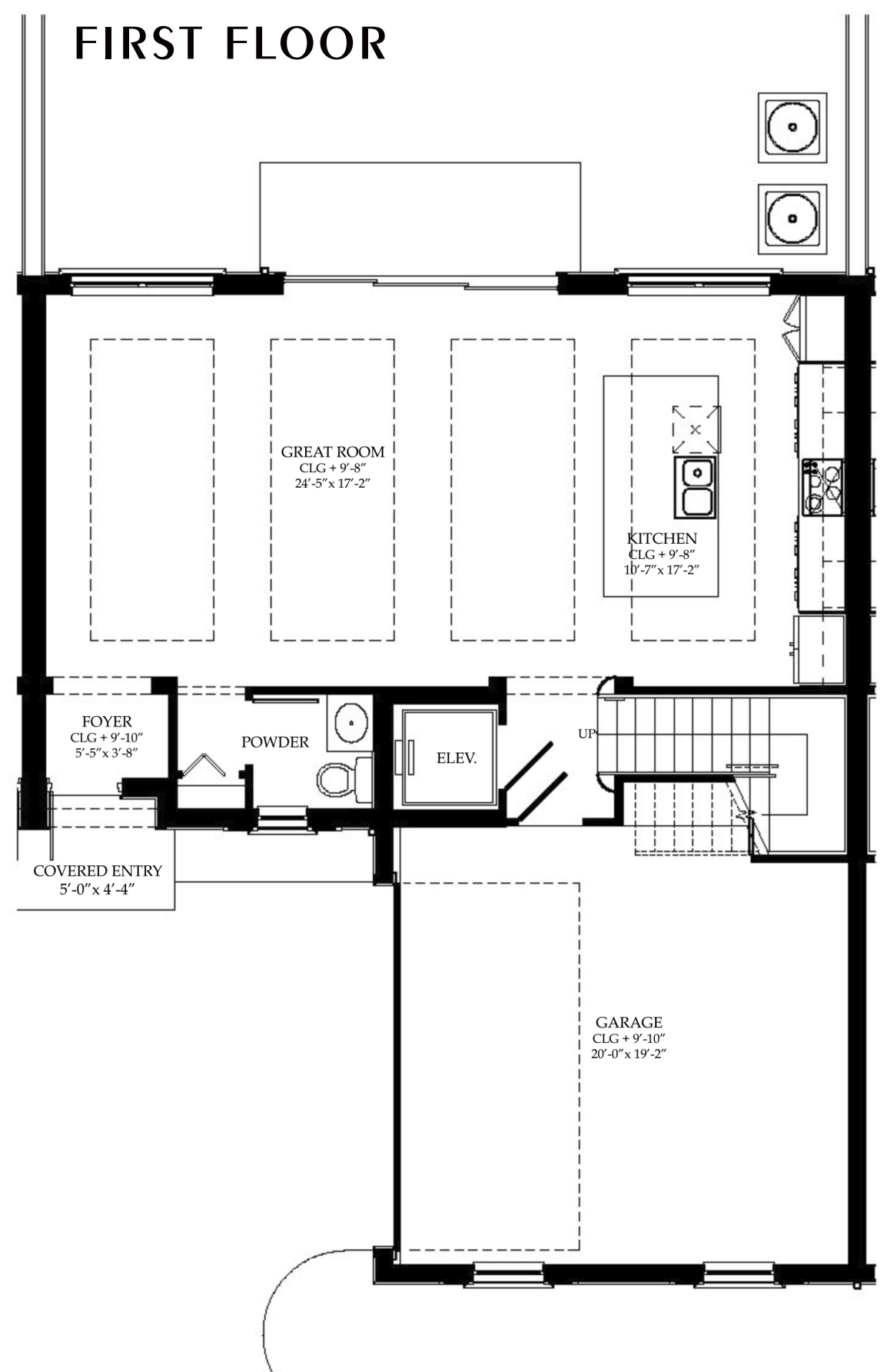

## SECOND FLOOR

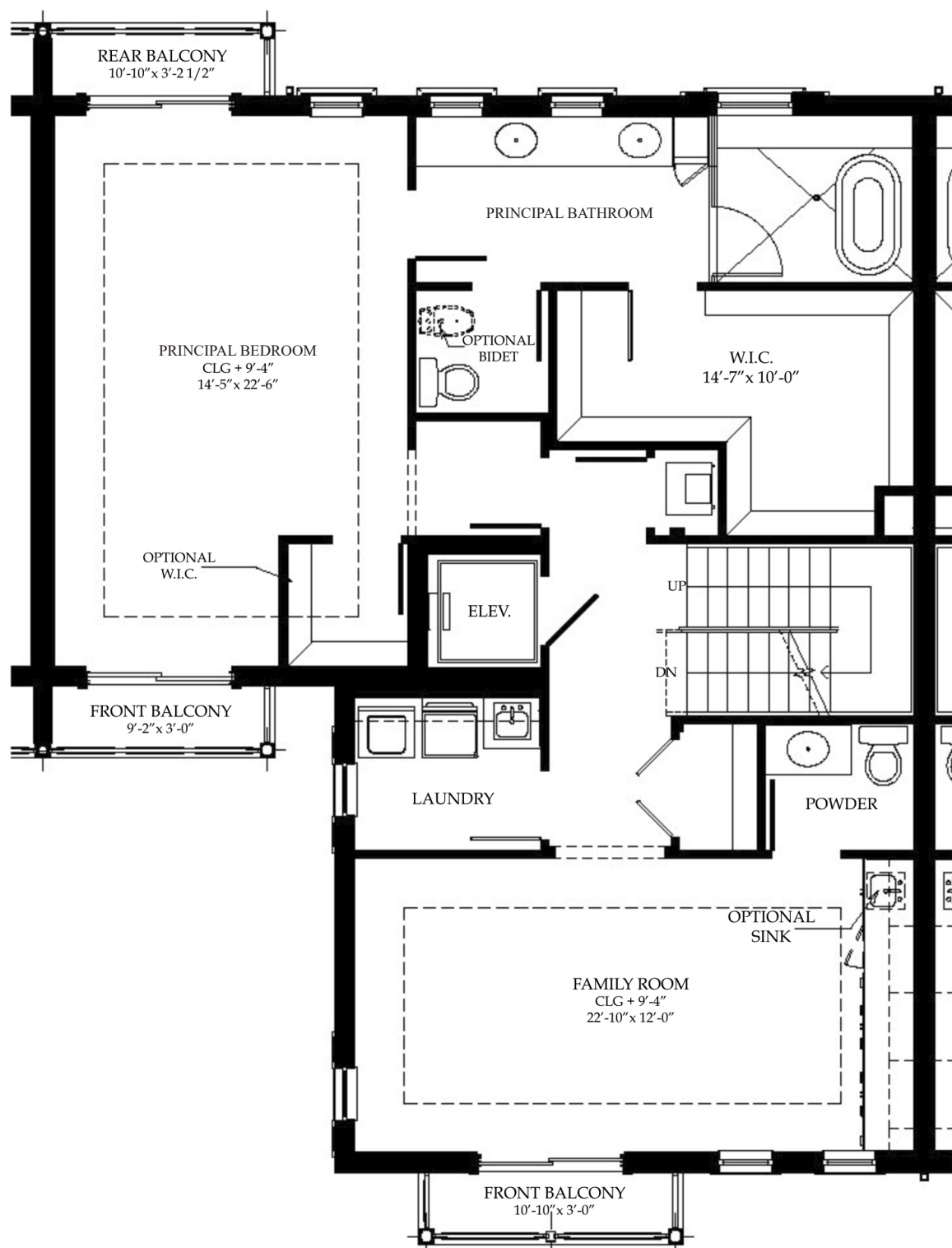

## THIRD FLOOR

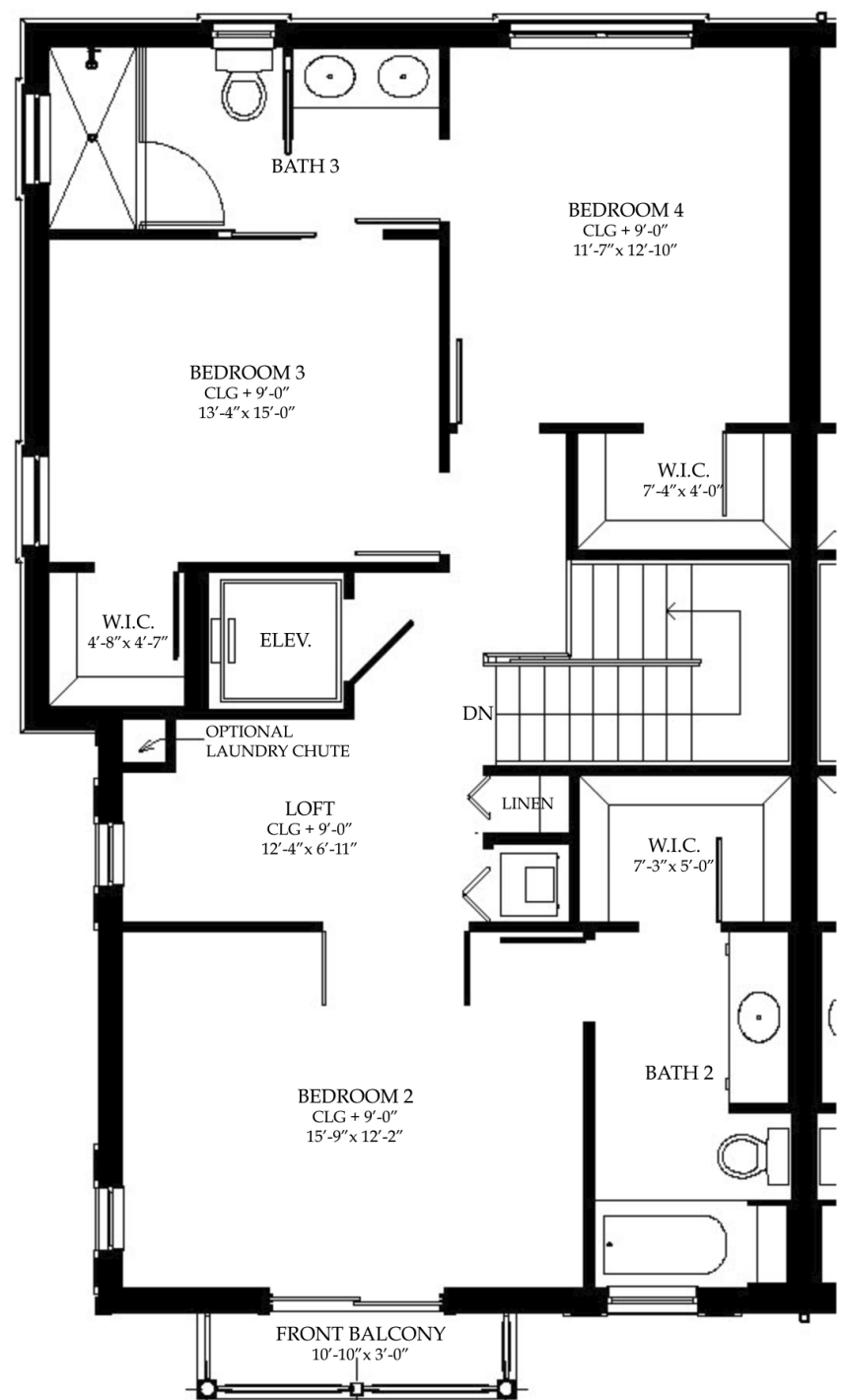

# CYPRESS

FAMILY ROOM



KITCHEN



PRINCIPAL BATHROOM



# SPRUCE

## Model units: 2

4 Bedrooms  
 3 Bathrooms  
 2 Powder Rooms  
 Media/Family Room

AC	NON AC	TOTAL
2,858 Sq.Ft.	593 Sq.Ft.	3,451 Sq.Ft.
265.5 Sq.Mt.	55 Sq.Mt.	320.6 Sq.Mt.

## FIRST FLOOR

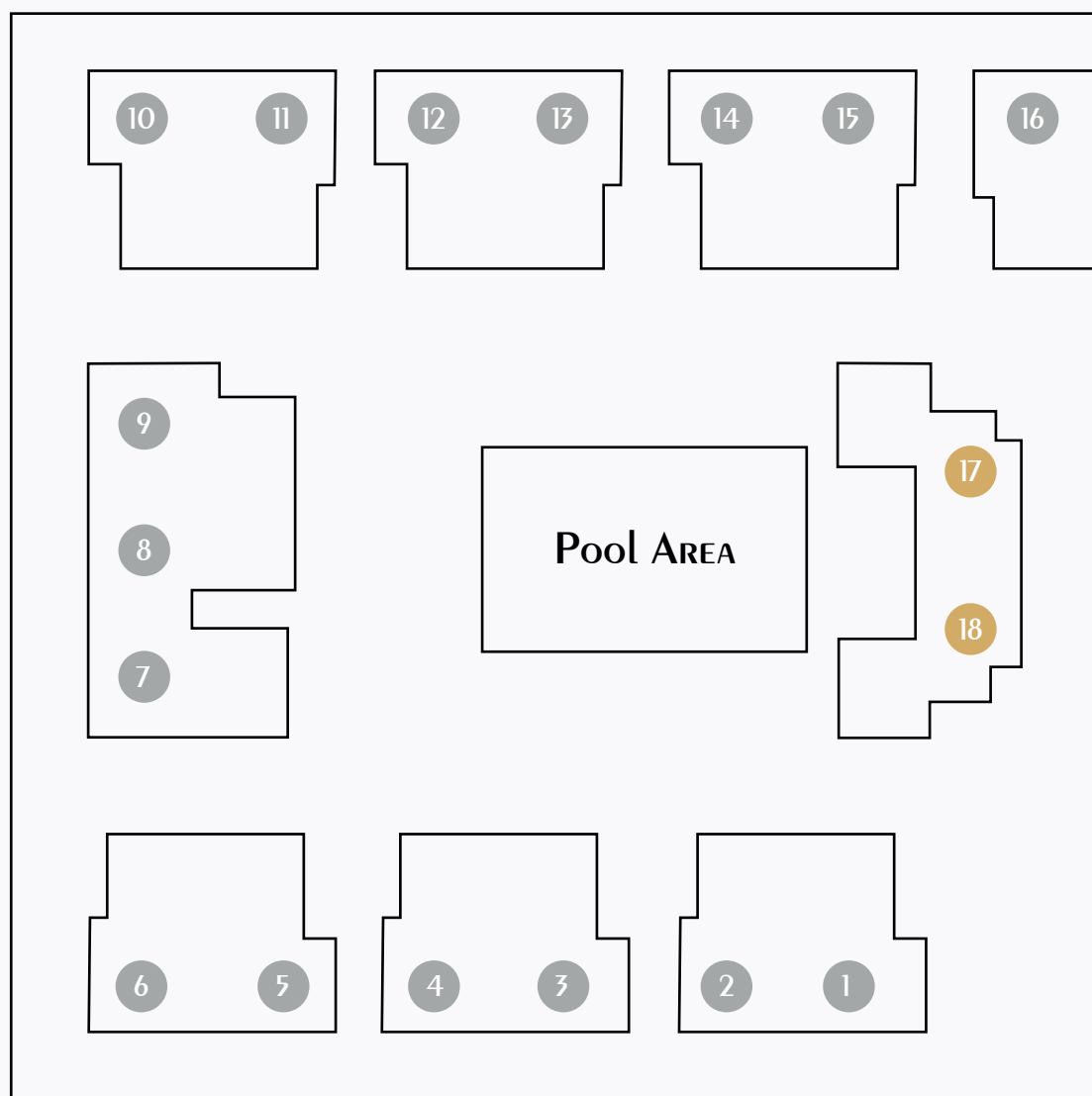

● Spruce



## SECOND FLOOR



## THIRD FLOOR



# SPRUCE

KITCHEN



PRINCIPAL BEDROOM



FAMILY ROOM





# FEATURES & AMENITIES

## INTERIORS

- Coffered Ceilings in Living Areas and Floating Ceilings in Principal Bedroom
- Impact Resistant Windows and Doors
- Top Quality Porcelain Material and Installation
- 9' Custom Sliding Doors in Great Rooms
- Spacious Walk-in Closets
- Designer Coordinated Lighting Package
- Linear Diffuser Air-Conditioner Grills in Common Areas and Principal Bedroom
- 7" Wood Baseboards
- Interior Pre-Hung Solid Core Doors
- Sherwin Williams Flat Latex Paint
- Pre-Wiring for Cable, Phone and Internet in Family Room and Bedrooms
- Audio and Video Standard Wiring in Three Locations
- Dual High Efficiency Air Conditioning Units
- Remote Controlled Garage Door
- Front Loader Washer and Duet Steam Dryer
- Tankless Gas Water Heater
- Full Security System with Siren, Motion Detector and Cellular Connectivity
- Elevator with finished passenger cabin

## BATHROOMS

- Top-Quality Fixture Package
- Countertop Basin Sinks
- Modern Quartz Countertops
- Frameless Glass Shower Enclosures
- Mia Cucina Cabinets

## KITCHEN

- Wolf Sub-Zero Luxury Appliance Package
- 36" Refrigerator with Dispenser
- Wolf 36" Pro Electric Range/ Oven
- 42" Exhaust in Ceiling
- Wolf 24" Microwave Drawer
- Sub-Zero 24" Under Counter Wine Cooler
- ASKO 24" Dish Washer
- Top-Quality Fixture Package
- Mia Cucina Italian Kitchen Cabinets
- Standard Hardware for All Cabinetry
- Quartz Countertops (Standard Selection)
- Sub-Zero 24" Refrigerator in 2nd Story Kitchenette

## EXTERIORS

- Aluminum Windows
- Sherwin Williams Acrylic Flat Paint
- Brick Paver Street and Driveway
- Landscaping with Automatic Sprinklers
- Flat Concrete Roof Tiles
- Aluminum Louvered Accents
- Insulated Aluminum Garage Doors
- Decorative Siding
- Private Backyards
- Secure Intercom Access

# ALL WITHIN REACH

Pine Park Villas is setting the new standard for luxury, town home living in one of the most desirable neighborhoods in South Florida. An ideal suburban village, Pinecrest boasts close proximity and easy access to Biscayne Bay, extraordinary public parks, great shopping, and some of the finest public and private schools in the southeast.

The Village of Pinecrest was recognized as one of the ten best places in Florida for overall quality of life by the South Florida Business Journal. Pine Park Villas provides an ideal Pinecrest address with easy access to Downtown Miami, Coral Gables, and Miami International Airport. Enjoy all of this convenience, and the simplicity of town home living, in this exciting addition to Pinecrest's limited collection of suburban multifamily residences.



## SCHOOLS

- 1 Pinecrest Elementary School
- 2 Palmetto Middle School
- 3 Palmetto High School
- 4 Gulliver School
- 5 Riviera Day School

## HOSPITAL

- 6 Baptist Hospital
- 7 South Miami Hospital

## SHOPPINGS

- 8 Dadeland Mall
- 9 The Falls
- 10 The Shops at Sunset Place
- 11 Suniland Shopping Center

## PARKS

- 12 Matheson Hammock Park and Marina
- 13 Pinecrest Gardens
- 14 Fairchild Tropical Botanic Garden
- 15 Flagler Grove Park
- 16 Coral Pine Park

# TEAM

**SCAROF A Properties, LLC** is a third-generation family business that has been heavily involved in various industries in Haiti, such as manufacturing business, land investment, and the oil industry.

With their business experience, their vision is to be a Real Estate development company distinctively known for its superior value delivery to customers, investors, and employees. Pine Park Villas is their first project in the U.S., using innovative and dynamic techniques to develop the most luxurious community with 18 properties in the Pinecrest area. With a deep-rooted commitment to quality and value, they've brought together the best sales team, construction team, architect, and design team to deliver their clients unmatched homes, providing them the individual attention and service they deserve.

Recognized as one of the Top 20 Building Companies in Miami, **GC3 Development** is a family operated business that traces back its roots a couple of generations to founder Pedro Garcia-Carrillo and son Michael Garcia-Carrillo. Together they have created a portfolio of over a thousand homes including some of South Florida's most distinguished projects in the last three decades. GC3 Development has spearheaded and successfully zoned, platted, constructed, and sold boutique-sized luxury communities and large home subdivisions throughout South Florida, all leaving an impression like none other. Under their "never compromise on quality or customer service" philosophy, the team opts to work closely with their clients to ensure a satisfying home buying experience.

# TEAM

**Miami Architectural Studio** is an innovative residential design firm recognized for creating elegant and sophisticated spaces. Their designs take form by understanding client visions and guiding them through the entire process until ideas become reality. MAS+ strives to create intimate spaces and ambiances that reflect client's goals, priorities, lifestyle and particular taste. For over 30 years MAS+ has shaped South Florida's residential needs. Their architectural and planning portfolio ranges from custom homes, residential developments, mixed-use buildings, office buildings, and recreational facilities. MAS+, is always committed to excellence and building long-term relationships.

**Residence Realty** prides itself on being a leader in pioneering the sales of new products in emerging and established neighborhoods. The company has grown through its expanding international network of buyers and sellers. They also create ongoing new opportunities by cultivating authentically genuine relationships with developers, architects, investors, and real estate firms that are crucial to the success of their clients and partners. With over \$105M in total sales and over 230 transactions, Residence Realty has become a leader in South Florida real estate.

# TEAM

Paola Garcia-Carrillo founded and leads the Residence Realty Team. Paola is a highly-skilled, trained, and experienced real estate professional, having sold many developments & homes in the South Florida market and has become a leading provider of real estate services in the Miami Market. The team is dedicated to delivering the ultimate level of service and tech-savvy marketing expertise to the real estate market in South Florida.

“Our excellent reputation, passion, integrity, and transparency in the industry, with referrals from existing clients, are the foundation upon which our team is built,” said Paola Garcia-Carrillo.

# Pine Park

VILLAS

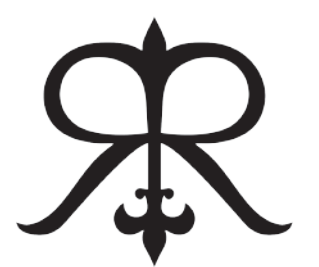

RESIDENCE  
REALTY



EQUAL HOUSING OPPORTUNITY. BROKER PARTICIPATION WELCOME. ORAL REPRESENTATION CANNOT BE RELIED UPON AS CORRECTLY STATING THE REPRESENTATION OF THE DEVELOPER. FOR CORRECT REPRESENTATION, MAKE REFERENCE TO THE DOCUMENTS REQUIRED BY SECTION 718.503 FLORIDA STATUTES, TO BE FURNISHED BY THE DEVELOPER TO A BUYER OR LESSEE. NOT AN OFFER WHERE PROHIBITED BY STATE STATUTES. ALL ILLUSTRATIONS, FLOORPLANS, AND SQUARE FOOTAGE ARE ARTISTIC CONCEPTUAL RENDERINGS AND ARE SUBJECT TO CHANGE WITHOUT NOTICE. MARKETING & ADVERTISING BY CREATIVE MINDWORKS